

An Unusual Crankshaft and How It Is Made

By J. A. LUCAS

An outline of the machine and methods used in making the Lancia crankshaft from a solid forging, this construction being necessary by the staggered cylinders

THE use of staggered cylinders, as has been previously described, necessitates very close crankpin bearings and makes the usual type of forged crankshaft impossible. In order to secure crank webs thin enough to permit the close center distances, the crankshaft is turned from a solid forging of chrome-nickel steel. The forging is heat-treated at a temperature of 1,475 deg. F., and is tempered in oil, so as to secure a tensile strength of approximately 140,000 lb. per sq.in. After the centers have been carefully located so as to insure proper distribution of stock, the shaft end is turned on the lathe shown in Fig. 1. The tool block is so constructed as to clamp small cutting tools, as at *A*, on narrow supports in order to permit the tools to be fed in on each side of a flange. This tool block can be readily reversed and the large clamping nut *B* is an indication of its rigidity. There is also another tool block at *C*. The end flanges are faced and the ends and the center bearing are turned before leaving the machine. The sides of the end flanges and the forged blocks are milled in the milling machine shown in Fig. 2, the fixture holding three shafts. The shafts are clamped by the end bearings and are supported from underneath. The screws, as at *A*, raise the supporting blocks *B* into contact with the forging so as to support it during the milling operation. The adjusting screws are locked by the cross screws *C* after adjustment has been completed. The crankshafts are heat-treated and then returned to the lathe department for final turning. Two of the turning operations

are shown in Figs. 3 and 4, both of which show crankpins being turned. The method of holding the crankshaft so as to secure the proper offset can readily be seen. The forging is held firmly and is supported close to the cut. A very ingenious arrangement is provided whereby the crankshaft is fed out of the chuck the desired amount, the tailstock being pulled back a corresponding amount at the same time. The method of feeding the crankshaft through the spindle is shown in Fig. 5, while Fig. 6 gives considerable detail as to the construction of the holding device.

The inner spindle that holds the crankshaft forging is in an eccentric sleeve which can be rotated so as to bring either the main bearing or any one of the crankpin bearings in line with the center of the spindle. The center attached on the outer end of the shaft is merely for support. The eccentric sleeve is fed through the main spindle by means of the rack *C* and the pinion *D*. Proper positioning of the crankshaft with regard to spacing the crank and the main bearing is secured by a substantial index pin at *E* and corresponding holes in the drum *A*. At the other end of the spindle are two hook shaped jaws *H*, with internally-threaded pinions on the inner ends, as at *J*. These jaws are operated by a gear on shaft *K*. Handle *L* at the other end, also shown in Fig. 5, controls the position of the jaws, turning them away to admit the crankshaft and closing them over the crankshaft flange for holding. Wheel *M* then draws the jaws in and holds the shaft firmly in place. The construction

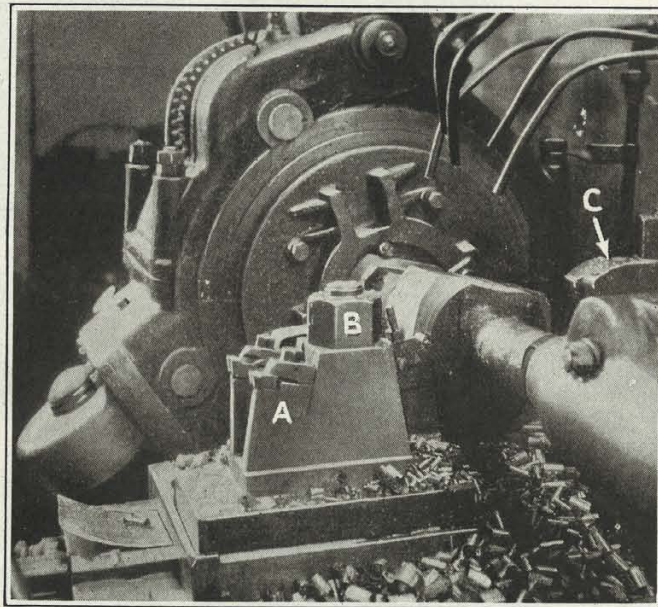

Fig. 1. First turning operation on crankshaft. The end flange is being faced and the end will be turned in this operation. The toolpost is somewhat unusual, carrying short pieces of high-speed steel on narrow supports to insure clearance between the flanges

Fig. 2—Milling the sides of the cranks after the end flange and main bearings have been roughed out. The crankshafts are located from these milled surfaces for future operation

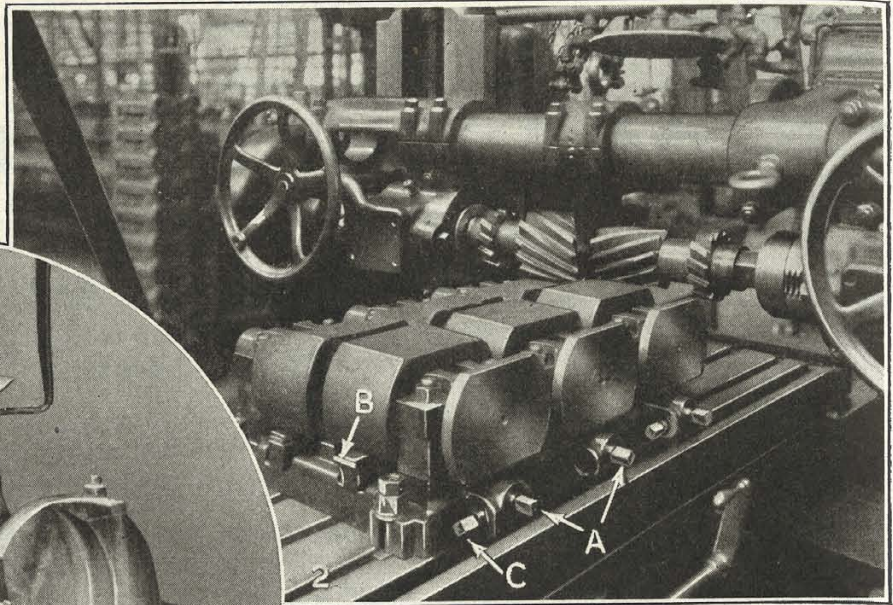
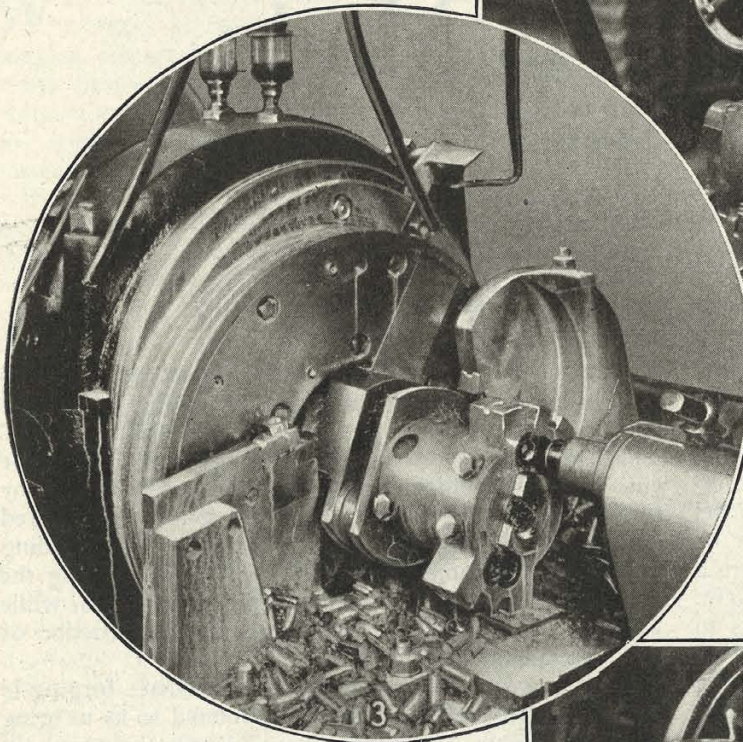

Fig. 3—Turning the crankpins. Here the shaft is mounted in a special lathe having a spindle with an eccentric sleeve so that the shaft can be swung to position for each crankpin. The shaft is supported close to the cut to prevent overhang and to avoid spring. The outer end is supported in the usual manner

Fig. 4—Another view of the same operation with the shaft extending out of the chuck in position for turning the third crankpin. This view shows how the two crankpins that are in line are turned at the same setting of the eccentric sleeve

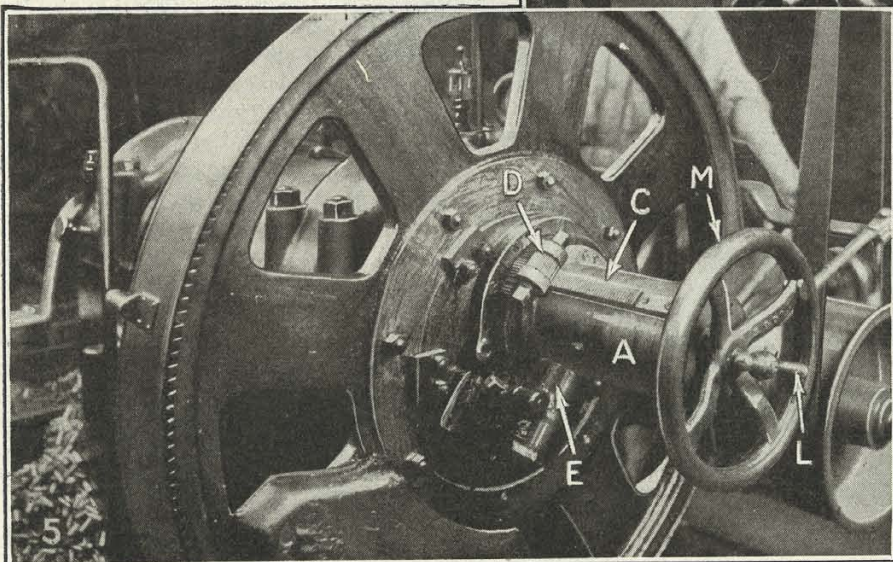
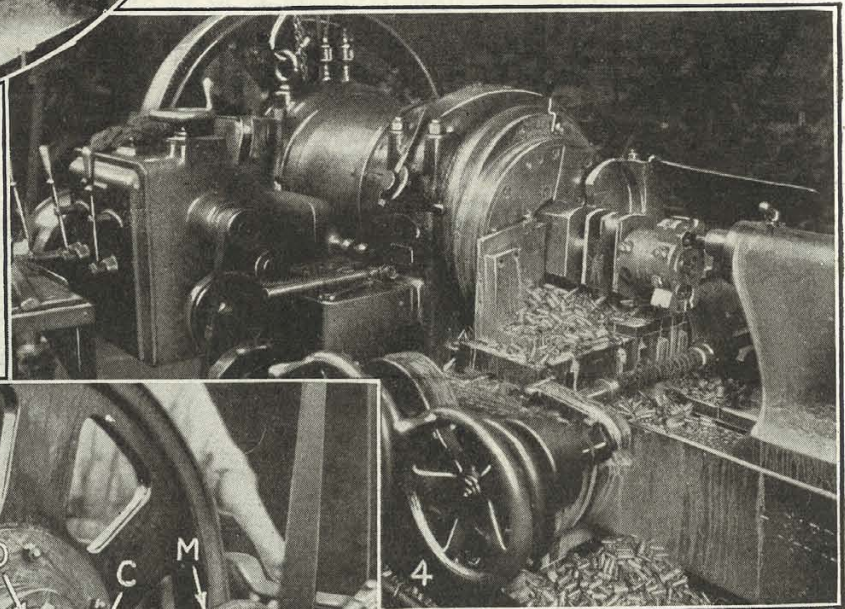
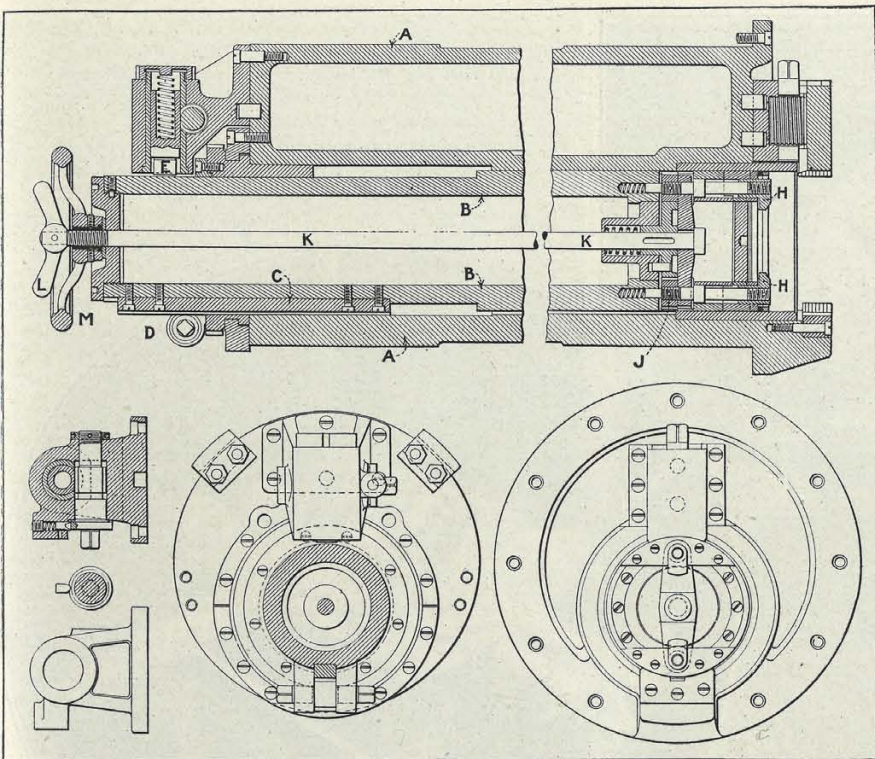

Fig. 5—Rear end of crankshaft lathe, showing how the eccentric sleeve is adjusted for different crank positions. One of the index holes that insure the different crankpins being located in the proper position, may be seen



supports by dovetailing, as can be seen at *A* and are fed forward as it becomes necessary by a screw at the back. The tools are sharpened by grinding the front ends to the proper clearance and are clamped at any desired adjustment by the screws *B*. The other tool is for facing down each side of the crankshaft webs, and follows the first tool. It has been found much more satisfactory to divide the work up in this way than to attempt to do it all with a single tool. In Fig. 16, details of the toolblocks are given. A central hole for lightening the weight of the crankshaft is drilled in the fixture shown in Fig. 8. Here the shaft is positioned by the two V-blocks *A* and is held by two clamps, one being shown at *B*. The second clamp is not in place but the clamping bolt is shown. The bolt holes are drilled in the flange for attaching the flywheel, in the fixture shown in Fig. 9. The construction of the fixture is shown too plainly to need special description. At the right is the fixture in which the crankshaft is held while oil holes are being drilled in the different bearings. This fixture is mounted on the regular table

Fig. 6—Details of the crankshaft positioning mechanism. The construction of the spindle and its eccentric sleeve is shown, as well as the method by which the crankshaft is indexed to center the pins with the spindle

of the toolblocks used in turning the different bearings on the crankshaft are shown in Fig. 7. They are specially designed to support the cutting tools firmly, and at the same time afford ample clearance on each side for the throws of the cranks. The tools are held in their

of the drilling machine and can be swung under the drill spindle after the other fixture has been removed.

Details of this fixture are shown in Fig. 10, which shows how the crankshaft can be positioned at any desired angle for the holes in the different crankpins and

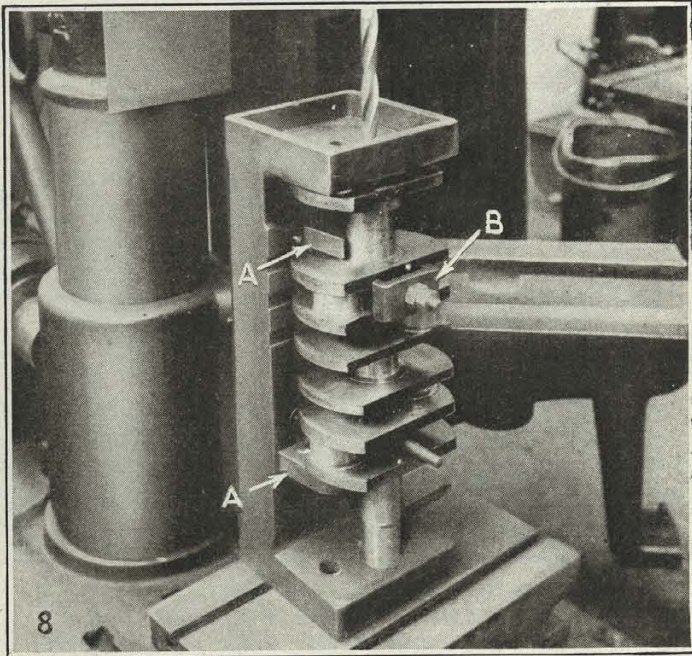
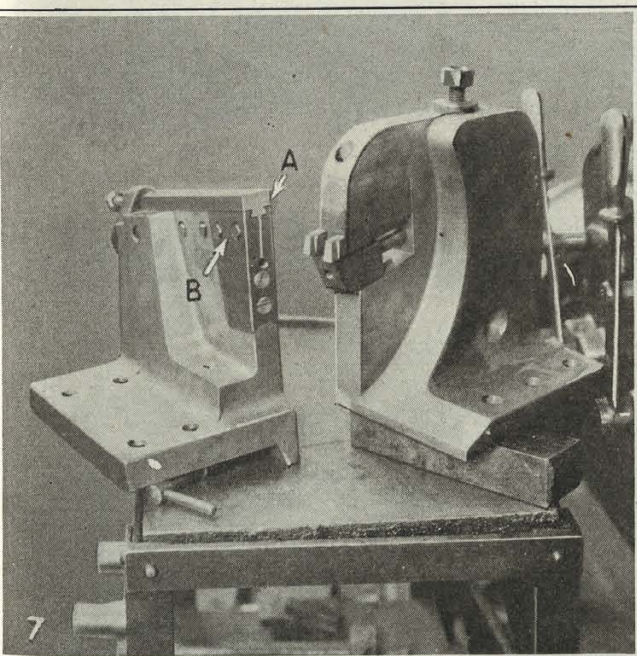

Fig. 7—Tools and toolholders for finish turning the crankshaft bearings. The tool at the left is dovetailed along its entire lower side and is fed forward into the work by a screw at the back.

This tool is closely followed by the two tools in the other block, which face down each side of the web. These tools have increased output and decreased tool cost. Fig. 8—Drilling a

hole through center of shaft for lightening its weight. This is a simple fixture and the way in which the crankshaft is positioned and held can readily be seen

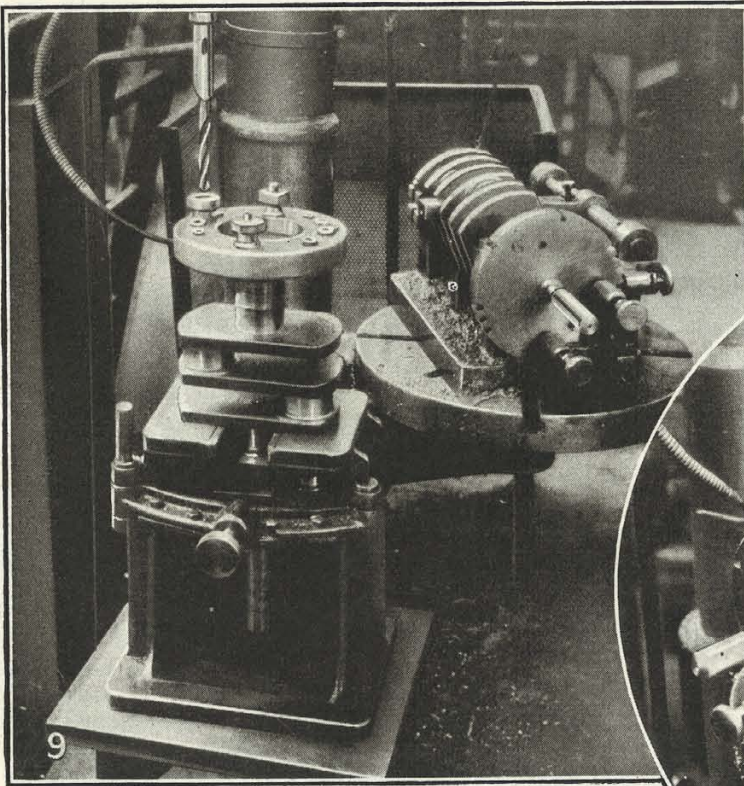

Fig. 9—Drilling the flange for attaching the flywheel. The method of supporting the crankshaft and attaching the drill gage block can be seen. This fixture is mounted on an auxiliary table so that by removing it the regular table and fixture at the right can be used

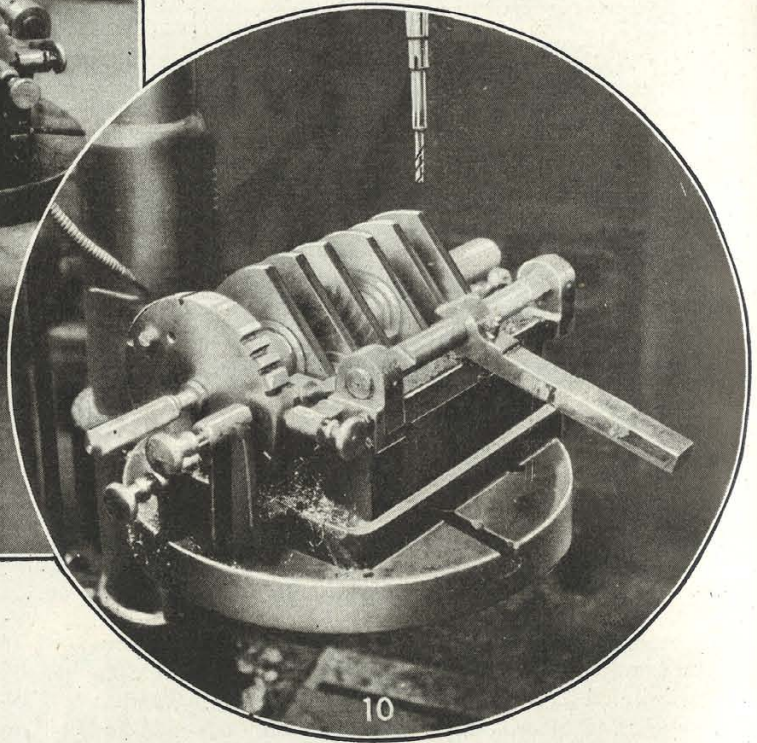

Fig. 10—Fixture for drilling oil holes in the various bearings. This view shows how the crankshaft is supported in the fixture and how it can be positioned at various angles so as to have the oil holes in the positions desired

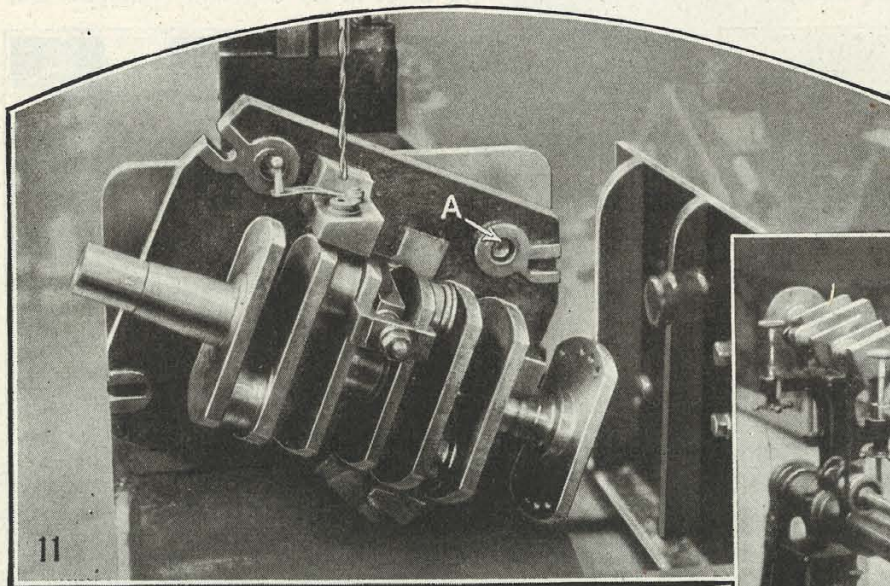
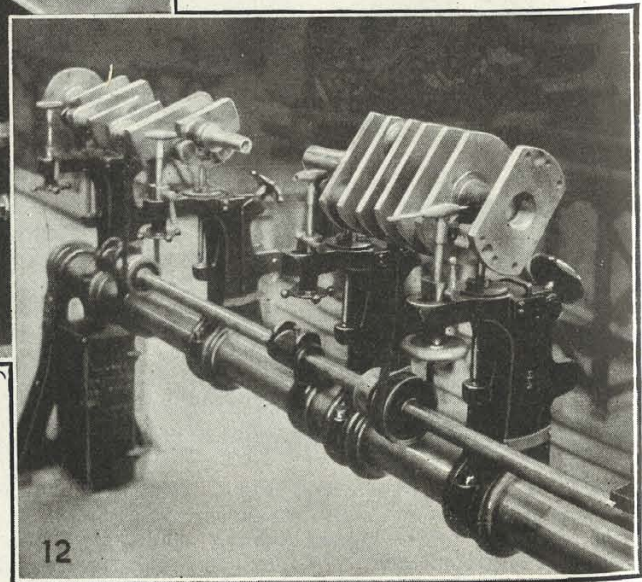
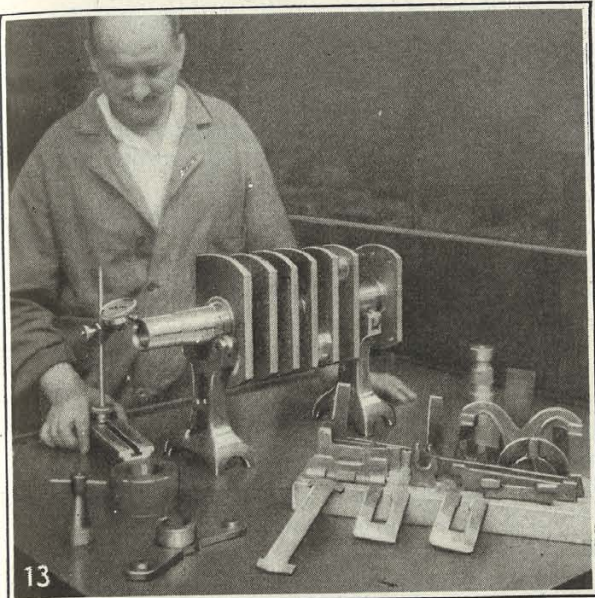

Fig. 11—Drilling oil passages from crankpin to main bearing. This fixture is pivoted in the center so that it can be revolved to drill the oil passage from the fourth crankpin to the rear main-bearing

Fig. 12—Balancing the finished crankshaft on a Norton machine. The crankshaft is revolved on rollers by a belt from the shaft below to the central main bearing





13

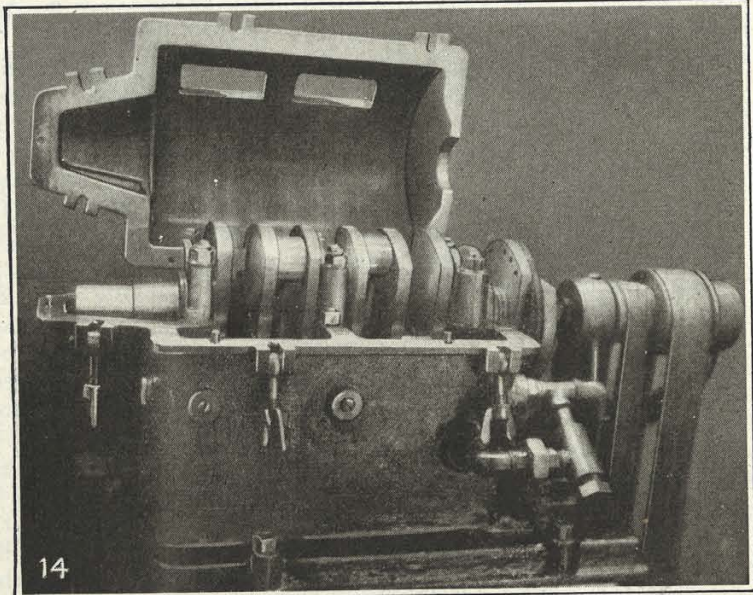

14

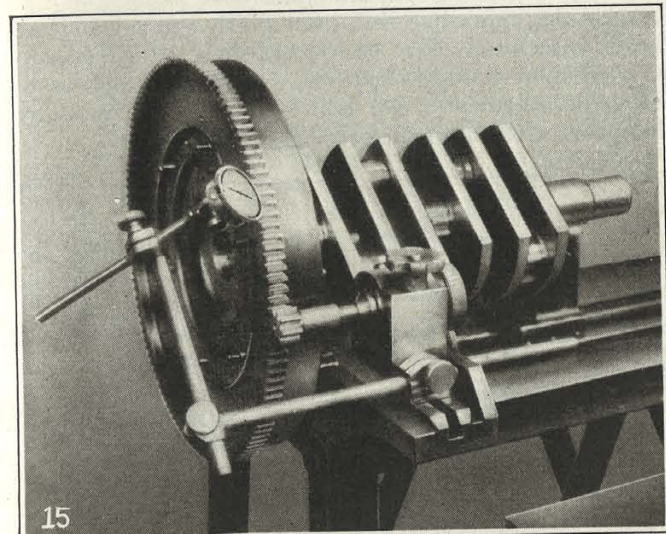

15

Fig. 13—Inspecting the completed crankshaft. The inspection bench, the method of mounting the crankshaft and the 24 gages used in inspecting the various dimensions. Extreme care is exercised in securing both concentricity and parallelism of the various bearings

Fig. 14—Washing the crankshaft before assembly. The shaft is mounted in a special crumple that is filled with a washing compound, and in which the shaft is revolved through the belt at the right

Fig. 15—Checking the concentricity and the bearing of the starting gear and pinion. After the flywheel has been bolted to the crankshaft, it is mounted in the fixture shown to test its truth and that of the starter gear

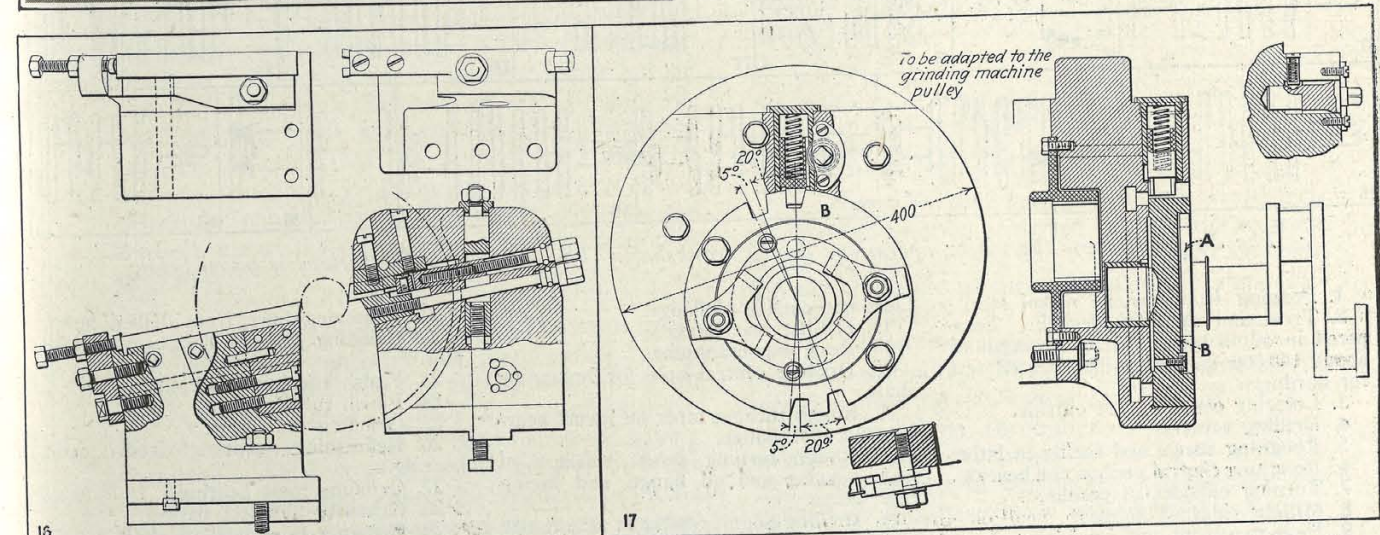

16

17

Fig. 16—Details of the toolblock. The drawing shows the manner of holding the tools in both front and back positions, and of securing the adjustment

to compensate for resharpening. Fig. 17—Fixture for holding crankshaft for grinding crankpins. The angularity of the cylinders makes it necessary to

offset the crankpins. The index plate and pin locate the shaft in the correct positions, successively, for grinding each of the crankpins

main bearings. Another fixture for drilling oil passages is shown in Fig. 11. Here an oil hole is being drilled from the second crank pin through the third web and into the central main bearing. This fixture is indexed by a pin as at *A* and can readily be swung into the opposite position for drilling from the third crank pin back to the center bearing.

After the usual finish grinding of the crankpin and the main bearings, the final milling cut is taken on the sides of each web, the crankshaft being located from the bearings that have been finish ground. This final milling operation has been found to assist greatly in securing the desired balancing of the complete crankshaft. A special fixture is used in grinding the crankpins so as to index them to match the angularity of the cylinders. Details of the fixture are shown in Fig. 17. The finished shaft is then balanced on a Norton machine as shown in Fig. 12, where two shafts are shown in place. The shaft is then ready for inspection.

Anyone familiar with crankshaft inspection methods can readily follow the inspection of the shaft in Fig. 13 by a careful study of the various gages. One is impressed with the extreme compactness of the shaft and with the large diameters both of the crankpins and the main bearings. The shaft is mounted on portable stands carrying rotors so that it can be conveniently turned.

After inspection, the crankshaft is thoroughly washed

by being mounted in the special crankcase shown in Fig. 14. The flywheel flange is driven by means of a friction disk at the right and the cleansing solution is forced through all of the oil passages. This operation thoroughly washes out all of the oil passages and insures their being clean so that there will be no question as to oil reaching every bearing surface.

After the flywheel and crankshaft have been assembled, the flywheel is tested as in Fig. 15, with both an indicator and a dummy starting gear. This combination checks the concentricity of the flywheel and gear and also checks the gear teeth as to contour and back lash.

The angularity between the two sets of cylinder bores makes it necessary to have the crankpins correspond. Hence the indexing arrangement on the crankshaft lathe, as in Fig. 5. In grinding the crankshafts, it is necessary to maintain the same offset indexing of the pins, the fixture for this operation being shown in Fig. 17. This fixture holds the shaft in the proper position for crankpin grinding, the flange being held as at *A*. Then by indexing the carrying plate *B* the crankshaft can be turned to grind any one of the four crankpins.

After the crankshaft has been finish ground and the various dimensions have been checked in the usual manner, it is subjected to an extremely rigorous inspection to determine whether or not each crankpin is in accurate alignment with the main bearings.

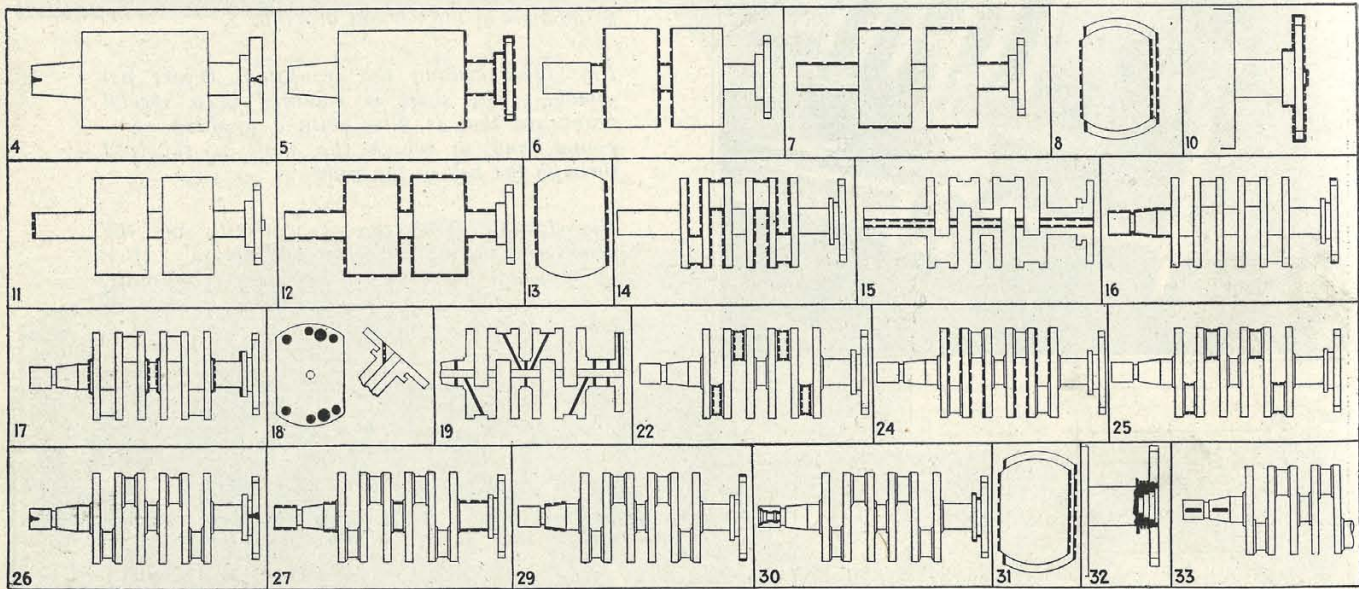

The diagrams show the major operations on the crankshaft. The sequence of operations is given below

1. Forging from chrome nickel steel.
2. Treatment at 1,470 deg. F. Tempered in oil in secure tensile strength of about 140,000 lb. per sq.in. Brinell test for hardness.
3. Locating centers from outside.
4. Drilling centers.
5. Roughing flange and facing in lathe.
6. Roughing central portion and bearing.
7. Turning outsides of cranks.
8. Milling sides of flanges.
9. Heat-treatment and hardening.
10. Finish turning flange.
11. Remove center bosses and finish end to length.
12. Grinding center journals, flange

- faces and outside of flange.
13. Milling rear flange.
14. Roughing crankpins.
15. Drilling central hole for lightening shaft.
16. Rough turning taper on thrust bearing and rear flange.
17. Rough turning thrust washers of main bearing and oil flange, and facing rear flange.
18. Drilling angular holes in rear flange and locating points for oil passages from pins to main bearings.
19. Drilling central oil holes.
20. Drilling rear flange and angular hole to crankpin.

21. Removing burr from drilled holes.
22. Grinding sides of flanges of crankpins.
23. Finish turning crankpins.
24. Finish turning crank webs.
25. Grinding crankpins.
26. Refinishing centers from main bearing.
27. Grinding main bearing.
28. Grinding flywheel flange.
29. Grinding taper end of shaft.
30. Finish grinding oil flanges.
31. Finish milling flanges.
32. Threading oil retainer on bearing.
33. Milling keyways.
34. Complete inspection.